

Roller Bearing PULLER/INSTALLER

(Railroad Edition)
100 Ton Pulling
Capacity

BEARING MAINTENANCE



Our roller bearing pullers are ideal for replacing tough, worn-out bearings on RR freight cars.



The photo above shows the Universal Puller in position on the roller bearing assembly, which is ready for removal.

- Quickly remove or install tapered roller bearings.
- Designed with cooperation of major bearing manufacturers.
- It's a fast, simple, one-man operation with 100-tons of pulling force provided.
- Completely portable for easy, convenient positioning and out-of-the-way storage.
- The standard in most wheel shops.

Universal railroad axle journal roller bearing puller/installer – For years, the standard in most wheel shops. Power Team now has four models to choose for greater flexibility. With both sling and jack models available and two pumps to choose from, you can tailor the unit to match your needs. With the proper equipment and know-how, removal and installation of axle journal roller bearings takes an absolute minimum of time and effort.

Each unit will service a full line of bearings with rotating end caps, from class B thru GG. No other method can match Power Team's simplicity. Removal is very easy. Simply remove the end caps, slip the pulling shoe between the bearings and the wheel, actuate the pump, and in seconds, 100 tons of pulling force removes the bearing. Installation is just as easy! Each unit is CSA certified (LR19814) and comes complete with a heavy-duty 100-ton hydraulic cylinder, 10,000 PS.I. (700 bar) pump with remote control solenoid valve, hydraulic pressure gauge (No. 11543), a pulling shoe and installing tube.

Order No.	Model Type	Cylinder Type	Valve Type	Pump Information		
				H.P	Phase	Voltage
PR2100J	† Jack	Double Acting	Solenoid	2**	1	115 or 230*
PR3100J	† Jack	Double Acting	Solenoid	3	3	230 or 460*
PR2100S	† Sling	Double Acting	Solenoid	2	1	115 or 230*
PR3100S	† Sling	Double Acting	Solenoid	3	3	230 or 460*

* Prewired at factory for this voltage. Other voltages available upon request.

** The 1,49 KW, 115 volt requires 30 amp service.

Tooling order information - IMPORTANT..This tooling chart applies only to standard AAR configurations for freight care applications. In order to provide adapters needed to service housing-type locomotive and passenger car bearings, as well as metric bearings, Power Team must be provided with the following information: bearing manufacturer's name and general arrangement drawing number, size of bearing to be serviced, railroad name and location and part numbers of adapters already in your possession if you currently own a Puller/Installer.

Tool Description	Class and size of bearing assembly TBU & SP "Metric Tooling"			
	120	130	140	150
Pulling Shoe Insert Adapter	No. 351830	No. 30512	No. 30521	No. 30520
Guide Tube & Cap Screw Assembly	No. 253341	No. 253342	No. 253343	No. 253344
Cap Screw**	No. 253339	No. 253394	No. 253339	No. 253395
Guide Tube Adapter	No. 21247	No. 21247	No. 21247	No. 21247
Installing Tube Adapter Ring	No. 253335	No. 253336	No. 253337	No. 253338

** Screws are supplied with the guide tube and should be ordered as replacements only.



PR3100J



PR3100S

Tool Description	Class and size(mm) of bearing assembly to be serviced									
	Class B 108 x 203 (No.)	Class C 127 x 229 (No.)	Class D 140 x 254 (No.)	Class E 152 x 279 (No.)	Class EE 140 Axle. (No.)	Class EE 152 Axle. (No.)	Class F 165 x 305 (No.)	Class G 178 x 305 (No.)	Class G 165 Axle. (No.)	Class GG 165 Axle. (No.)
Pulling Shoe		No. 420845 is included as part of basic machine – Do Not Order						420846	420846	420846
Pulling Shoe	30522	30512	30521	30520	30520	30519	30519	—	—	—
Insert Adapter										
Guide Tube & Cap Screw Assembly	253313	253314	253317	253318	253316	253327	253320	253321	253319	253323
Cap Screw**	253156	253349	253308	253155	253307	253308	253310	253326	253309	253309
Guide TubeNo. Adapter	23934	21248	21248	21247	21247	21247	21247	21247	21247	21247
Installing Tube		No. 420845 is included as part of basic machine – Do Not Order						30417	30417	30417
Installing Tube Adapter Ring	21242	21258	21256-1	21255-1	21255-1	21257-1	21257-1	30586	30585	30585

Note: Adapters listed above are for servicing the following roller bearing assemblies: Brenco "Crown-Taper", New Departure-Hyatt "Hy-Roll Taper", SKF "Expediter" and Timken "AP".

** Screws are supplied with the guide tube and should be ordered as replacements only.

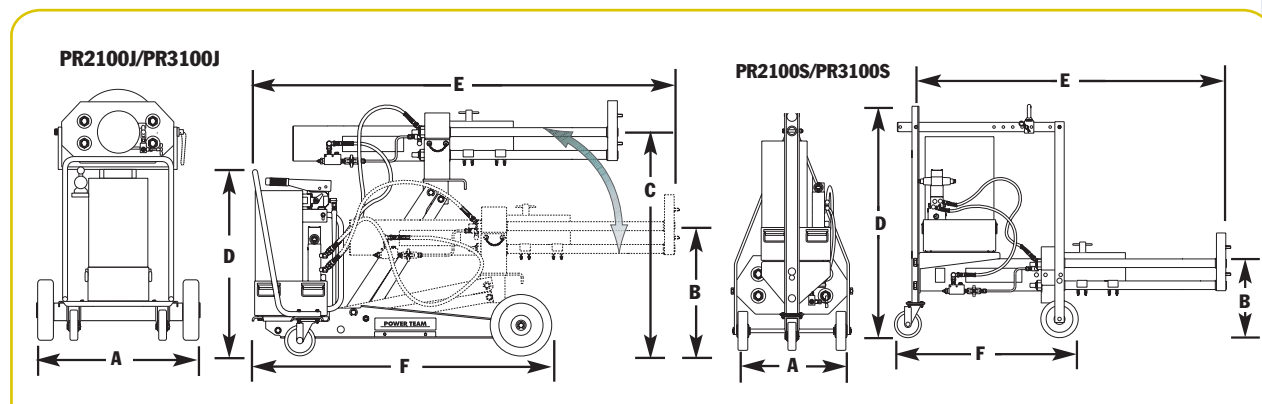

Order No.	Stroke (mm)	Capacity Pull (Tons)	Inst. (Tons)	Advance (mm/min.)	Speed		A (mm)	B (mm)	C (mm)	D (mm)	E (mm)	F (mm)	Weight (kg)
					Pull (mm/min.)	Inst. (mm/min.)							
PR2100J	394	100	68	900	81	113	813	383	1.059	912	1.981	1.493	528
PR3100J	394	100	68	900	81	113	813	383	1.059	912	1.981	1.493	520
PR2100S	394	100	68	900	81	113	619	279	—	1.283	1.632	985	455
PR3100S	394	100	68	900	81	113	619	279	—	1.283	1.632	985	458